

ORVSA 160

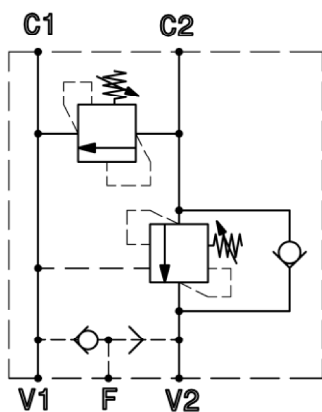
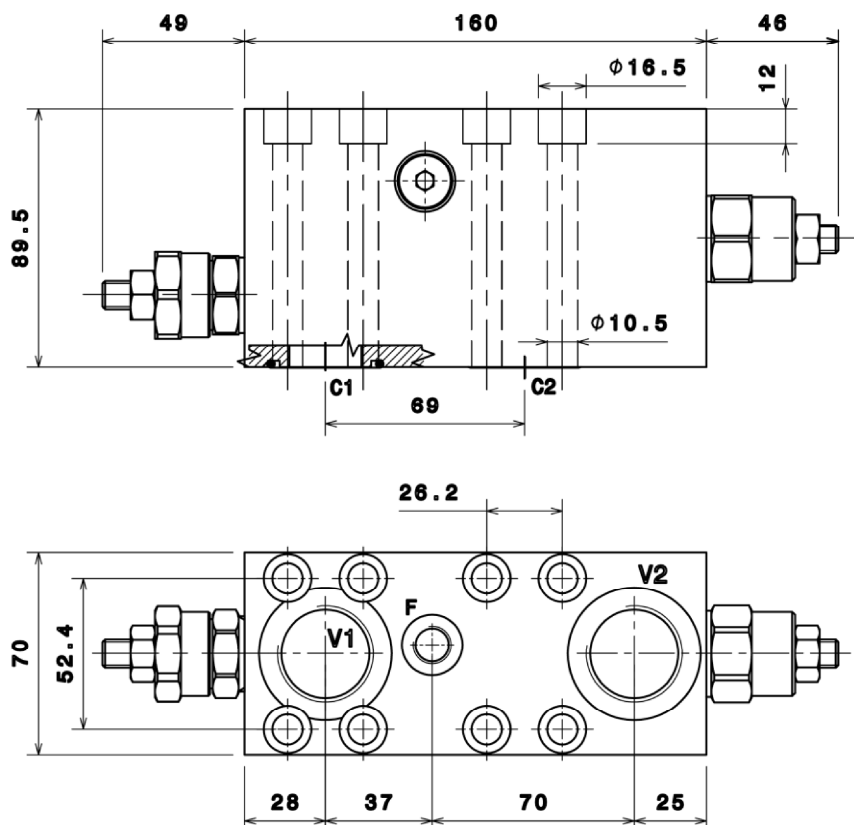

PORTS DIMENSION	
V1,V2	1" BSPP
C1,C2	O-Ring 2-126
F	1/4" BSPP

TECHNICAL DATA	
Material	Anodized aluminium corrosion resistant
Peak pressure	350 bar
Maximum pressure	300 bar
Maximum flow rate	150 l/min
Pilot ratio	1 3:1
	2 4.25:1
	3 8:1
	4 10:1
OVC relief valve setting range	A 20-200 bar standard setting 100 bar
	B 50-350 bar standard setting 280 bar
VLP relief valve setting range	A 20-100 bar standard setting 80 bar
	B 40-250 bar standard setting 180 bar
	C 60-350 bar standard setting 250 bar

Intermot distributor fitting

D47

ORVSA 300

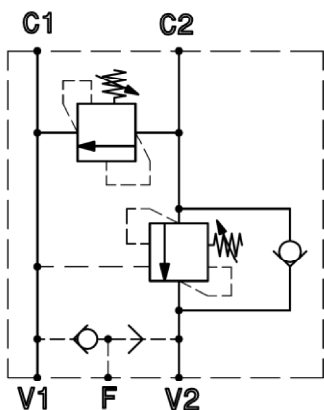
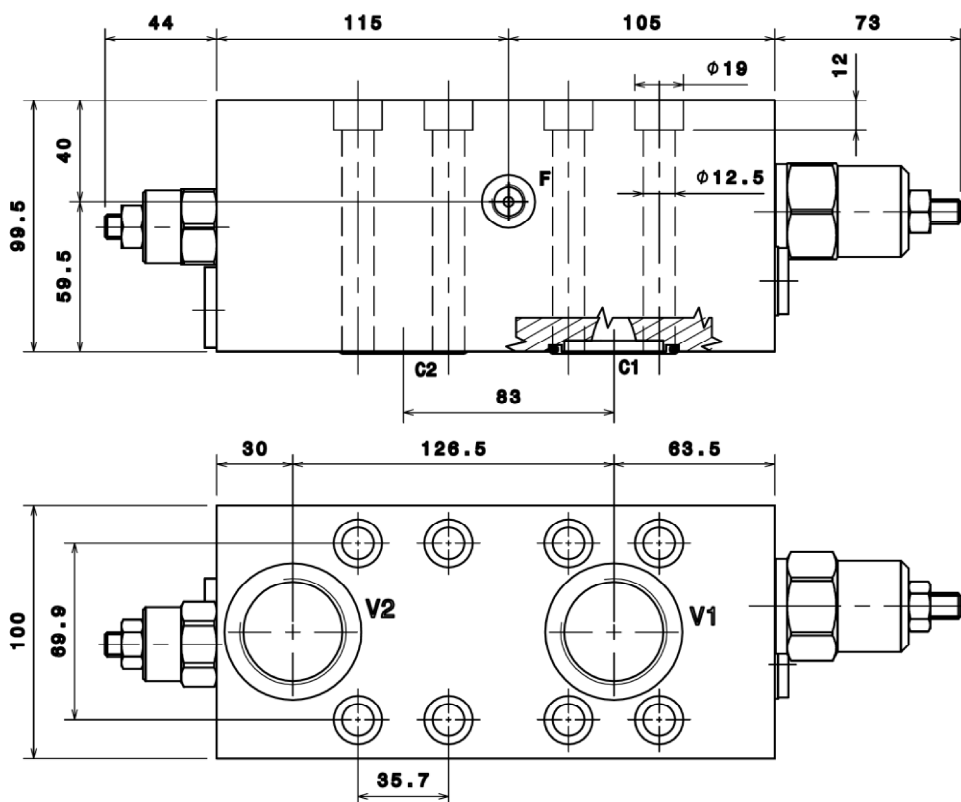

PORTS DIMENSION	
V1,V2	1"1/4 BSPP
C1,C2	O-Ring 2-224
F	1/4" BSPP

TECHNICAL DATA	
Material	Anodized aluminium corrosion resistant
Peak pressure	350 bar
Maximum pressure	300 bar
Maximum flow rate	300 l/min
Pilot ratio	1 3:1
	2 4.25:1
	3 8:1
	4 10:1
OVC relief valve setting range	A 20-200 bar standard setting 100 bar
	B 50-350 bar standard setting 280 bar
VLP relief valve setting range	A 20-100 bar standard setting 80 bar
	B 40-250 bar standard setting 180 bar
	C 60-350 bar standard setting 250 bar

Intermot distributor fitting

D75

ORVSA 480

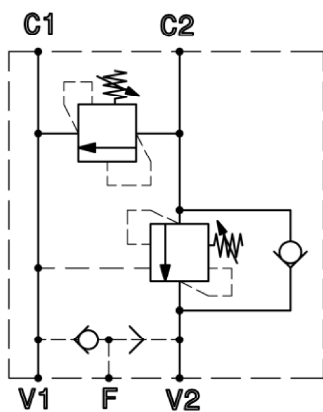
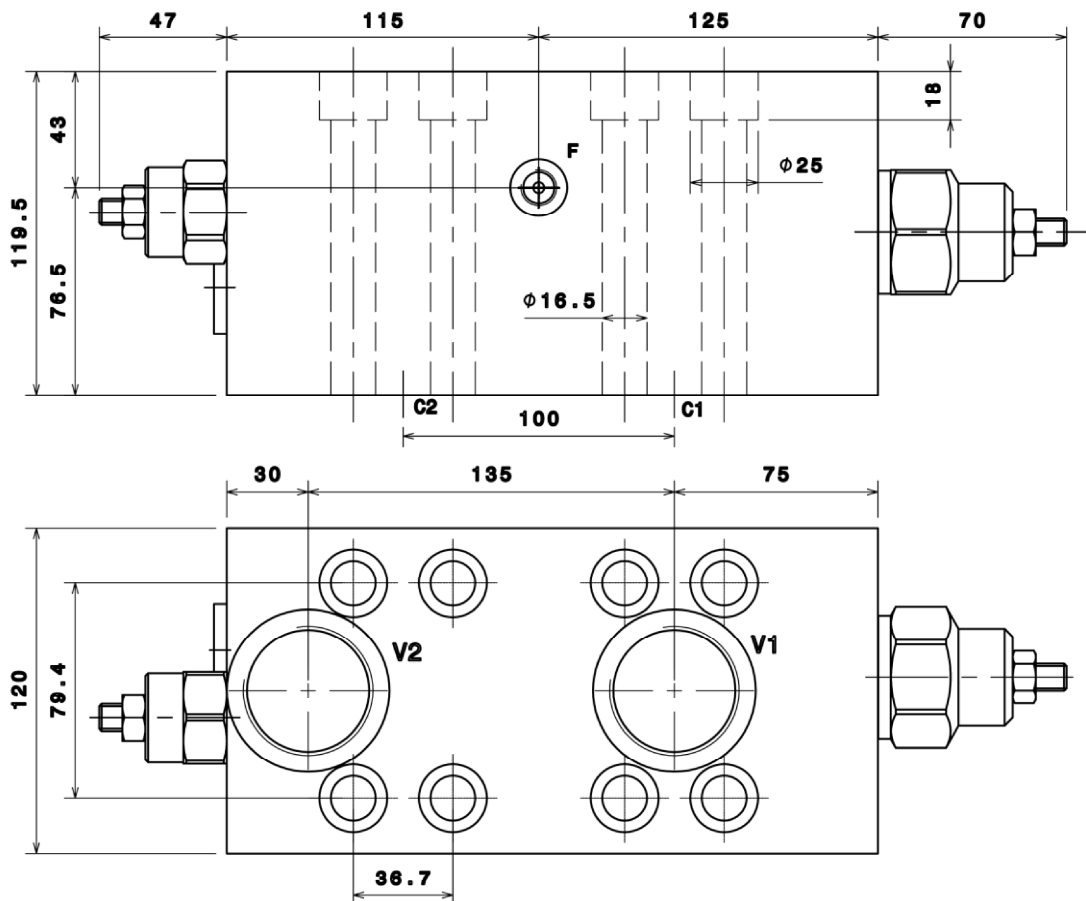

PORTS DIMENSION	
V1,V2	1"1/2 BSPP
C1,C2	O-Ring 2-225
F	1/4" BSPP

TECHNICAL DATA	
Material	Anodized aluminium corrosion resistant
Peak pressure	350 bar
Maximum pressure	300 bar
Maximum flow rate	480 l/min
Pilot ratio	1 3:1
	2 4.25:1
	3 8:1
OVC relief valve setting range	A 20-200 bar standard setting 100 bar
	B 50-350 bar standard setting 280 bar
VLP relief valve setting range	A 20-100 bar standard setting 80 bar
	B 40-250 bar standard setting 180 bar
	C 60-350 bar standard setting 250 bar

Intermot distributor fitting

D90